

PE VALVE TEE OPERATING INSTRUCTIONS

1. THREAD MALE PIPE THREAD BASE ON VALVE TEE INTO PREPARED METALLIC MAIN. THE TEE SHOULD BE THREADED INTO MAIN UNTIL SEAL HAS BEEN ESTABLISHED FOLLOWING YOUR COMPANY PROCEDURES.

NOTE: TORQUE SHOULD BE APPLIED TO METALLIC BASE TO OBTAIN LEAK FREE JOINT.

2. BY HAND, ROTATE OUTLET OF TEE TO DESIRED POSITION. THE METALLIC BASE SHOULD BE HELD IN POSITION DURING THIS OPERATION WITH A WRENCH. **DO NOT TURN OUTLET MORE THAN ONE FULL ROTATION.**

3. FOLLOW YOUR COMPANIES PROCEDURES FOR JOINING THE SERVICE LINE TO THE PE VALVE TEE OUTLET. THE SERVICE IS TO BE CONNECTED AFTER THE BRASS BASE TEE HAS BEEN CONNECTED TO THE MAIN FOLLOWING YOUR COMPANY PROCEDURES.

NOTE: THIS FITTING WAS DESIGNED TO BE USED WITH 1" IPS ELECTROFUSION FITTINGS.

4. ONCE THE SERVICE HAS BEEN ESTABLISHED, PRESSURE TEST ON THE NEW INSTALLATION CAN BE APPLIED. THE PRESSURE TEST SHOULD NOT EXCEED 150 PSI.
5. TO ALLOW FLOW THRU THE SERVICE USE A 3/8" ALLEN WRENCH AND TURNING COUNTER CLOCKWISE, BACK VALVE PLUG UP UNTIL IT IS FLUSH WITH TOP OF TEE. IT IS IMPORTANT THAT THE VALVE PLUG DOES NOT PROTRUDE ABOVE TEE.
6. VERIFY O RING IS IN PIPE CAP. INSTALL PIPE CAP ON TEE BODY AND SCREW DOWN HAND TIGHT. DO NOT USE WRENCHES ON PIPE CAP.

NOTES:

1. FOR SERVICE SIZES LARGER THAN 1", THE PHYSICAL STRENGTH OF THE PE VALVE TEE MIGHT BE LESS THAN THE PHYSICAL STRENGTH OF THE SERVICE LINE. IT IS ADVISABLE TO LIMIT LOADS WHICH MIGHT BE TRANSMITTED TO THE PE VALVE TEE BY THE SERVICE LINE. REFERENCE ASTM D 2774 "STANDARD PRACTICE OF UNDERGROUND INSTALLATION OF THERMOPLASTIC PRESSURE PIPING" FOR GUIDANCE ON THRUST RESTRAINT, BEDDING AND BACKFILL.
2. BRASS BASE SHOULD BE PROTECTED AGAINST CORROSION. FOLLOW YOUR COMPANIES PROCEDURES.
3. IT IS ADVISABLE TO LIMIT SHEAR AT MAIN CONNECTIONS. IN THIS REGARD, YOUR COMPANY'S POLICIES SHOULD BE FOLLOWED. FOR FURTHER INFORMATION, REFERENCE; ASTM D 2774 STANDARD PRACTICE FOR UNDERGROUND INSTALLATION OF THERMOPLASTIC PRESSURE PIPING; CODE OF FEDERAL REGULATIONS, TITLE 49, TRANSPORTATION PART 192; AGA PLASTIC PIPE MANUAL AND/OR THE GUIDANCE MANUAL FOR OPERATORS OF SMALL GAS SYSTEMS BY THE U.S. DEPARTMENT OF TRANSPORTATION.
4. **DO NOT TIGHTEN THE VALVE PLUG.** THE PE VALVE TEE IS SHIPPED WITH THE VALVE PLUG SEATED TO ALLOW A 150 PSI PRESSURE TEST THROUGH THE CAP OR SERVICE WITHOUT LEAKAGE INTO THE MAIN.
5. IF THE VALVE PLUG IS USED TO SHUT OFF AN ESTABLISHED SERVICE, DO NOT EXCEED 15 INCH-POUNDS OF TORQUE.

IMPORTANT

For use on:
Polyethylene gas pipe meeting the requirements of ASTM D 2513

Pressure Rating: 75 psig MAOP

Operating Temperature: -20 to 140° F

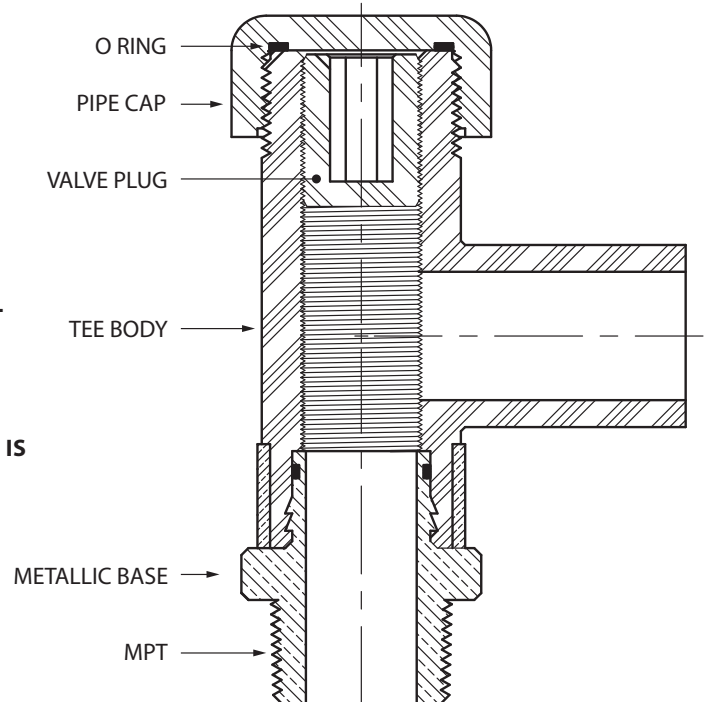

ECN 2620 REV "D" 07/22/14